

FRIGA-BOHN

MR | MRE

Höyrystin
Kaupallinen malli



CO₂
60 bar

CO₂
80 bar

A2L

HFC

W
GLYCOL



|||| 320 - 2760 W



- # Kompakti ja virtaviivainen muotoilu täydellisen integroinnin saavuttamiseksi pieniin tiloihin
- # Helppo asennus ja huolto pääsee helposti kaikkiin komponentteihin.
- # Harmoninen integraatio ympäristöön esteettisen suunnittelun ansiosta.
- # Vahva lamelli polyesterisuojauskella.

Puhaltimet

- # Puhallin 50-60 Hz, Ø 200 mm, Suojattu kotelolla, kytketty kytkentärasiaan (paitsi mallit MR 75/65).

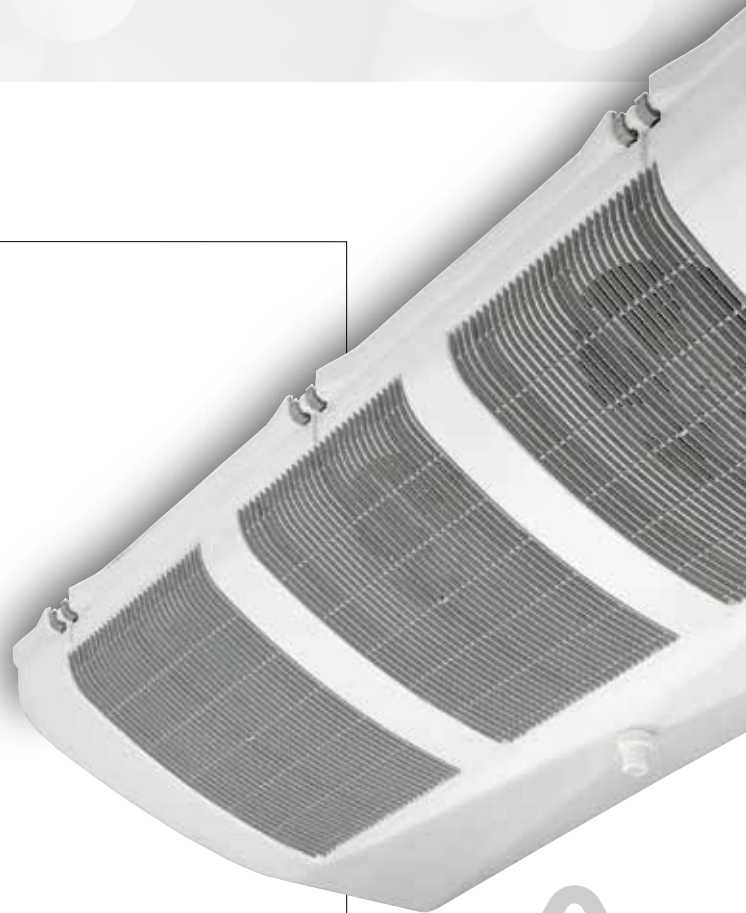

Kotelo

Kierrätettävä ABS -kotelo, takaa:

- # Korkea kestävyys lämpö- ja mekaanisille iskuille.
- # Täydellinen hygienia pyöristettyjen kulmien seurauksena, jotka poistavat retentiovyöhykkeet.
- # Ei teräviä reunoja lisäämään turvallisuutta.

Lisävarusteet

DMP

Paisuntaventtiili asennettuna

EEC

Höyrystin kokonaan varusteltu tehtaalla:

- Paisuntaventtiili
- Magneettiventtiili
- Putkisto varusteltu palloventtiilillä



Säästä aikaa asennuksen aikana valitsemalla nämä lisävaihtoehdot.



Sulatus

- # Sähkölämmitin lohkon alla olevassa lovessa, auttaen hävittämään lämpöä tasaisesti.
- # Kondenssiveden tyhjiönti tyhjennysaltaaseen
Suuri kondenssiveden yhde (Ø 1" G).

OPTIONS

THD
(MRE)

For cold rooms at negative temperatures, single pole reversing thermostat for defrost end at +12 °C (±3 K) and delayed ventilation restart at +2 °C (±3 K).
Supplied with a probe and a fixing bracket.

E1U

Light electric defrost.

E1K

Light electric defrost.

KIT TO INSTALL

	+10	+2	-5	-10	-25°C
ta1	MR ... R / L	+E1K E1U			MRE ... E / C

Select your coil treatment to extend your unit cooler's lifespan!
Contact us.

COILS

- # Aluminium fins with 4.23 or 6.35 mm spacing and sinusoidal profile.
- # Combined with copper tubes with a grooved internal structure, the coils are very efficient and compact.
- # Completely covered with polyester protection as standard.
- # Versions available:
 - Multi-refrigerant HFCs/A2L,
 - CO2 (60 or 80 bar).
 - WCO (glycol water, coolant).

MR_(A) 75_(B) R_(C)

- (A) MR = positive temperature without defrost
MRE = negative temperature with defrost
- (B) Model
- (C) Fin spacing: R = 4.23 mm (positive) E = 4.23 mm (negative)
L = 6.35 mm (positive) C = 6.35 mm (negative)

The MR | MRE is available with CO₂, A2Ls, HFCs and glycol water. For more information, please consult our software.

MR | MRE

 4.23 mm

CONDITIONS	REFRIGERANTS	MR ... R
SC2 (1)	CO ₂ - 60 bar (2)	W
	R449A	W
Connections HFCs	Inlet (3)	Ø ODF
	Outlet (3)	Ø ODF

75	110	135	160	180	210	270
600	930	1240	1440	1740	1970	2630
700	1060	1340	1600	1920	2170	2760
1/2" 12mm	1/2" 12mm	1/2" 12mm	D 1/2" *	D 1/2" *	D 1/2" *	D 1/2" *
3/8" 10mm	3/8" 10mm	3/8" 10mm	1/2" 12mm	1/2" 12mm	1/2" 12mm	1/2" 12mm

CONDITIONS	REFRIGERANTS	MRE ... E
SC3 (1)	CO ₂ - 60 bar (2)	W
	R449A	W
SC4 (1)	CO ₂ - 60 bar (2)	W
	R449A	W
Connections HFCs	Inlet (3)	Ø ODF
	Outlet (3)	Ø ODF

75	110	135	160	180	210	270
510	800	1060	1210	1470	1650	2190
520	770	1050	1190	1420	1660	2230
410	640	860	990	1200	1350	1790
410	580	830	940	1120	1310	1780
1/2" 12mm	1/2" 12mm	D 1/2" *	D 1/2" *	D 1/2" *	D 1/2" *	D 1/2" *
3/8" 10mm	3/8" 10mm	1/2" 12mm	1/2" 12mm	1/2" 12mm	5/8" 16mm	3/4" 18mm

Surface area		m ²
Circuit volume		dm ³
Airflow		m ³ /h
Fan 230V/1/50-60Hz 1,500 rpm	Air throw (4)	m
	Ø 200 mm	Nb
		W max
	230 V/1/50 Hz	A max (5)
Electric defr. MR > option EIK MRE > standard		Nb
	230 V/1/50 Hz	W
		A
Net weight		kg

75	110	135	160	180	210	270
3,4	3,7	6,1	6,0	8,0	10,1	13,4
0,6	0,6	1,0	1,0	1,4	1,7	2,3
290	650	580	880	880	870	1160
3,0	3,7	3,5	4,1	4,1	4,0	4,5
1	2	2	3	3	3	4
38	76	76	114	114	114	152
0,24	0,48	0,48	0,72	0,72	0,72	0,96
1	1	1	1	1	1	1
400	440	730	960	960	1200	1600
1,8	2,0	3,3	4,4	4,4	5,5	7,3
3	8	10	15	15	15	20

- (1) Standard conditions:
SC2 / 0 °C (air inlet temp.) / -8 °C (evaporating temp.) / DT1 = 8K
SC3 / -18 °C (air inlet temp.) / -25 °C (evaporating temp.) / DT1 = 7K
SC4 / -25 °C (air inlet temp.) / -31 °C (evaporating temp.) / DT1 = 6K
- (2) Operating pressure - Specific coil - Connection diameters to be defined when ordering.
- (3) ODF: female to receive the tube of the same diameter.
- (4) Residual air speed: 0.25 m/s.
- (5) Adjustment of overload protection. For air temperatures "ti" other than +20 °C, multiply the intensities by the ratio 293/(273 + "ti") to obtain the approximate value of the intensity after the room has been brought up to temperature.

* Distributor: Ø 1/2" male to solder. Connecting piece supplied for solder expansion valve Ø 12 mm.



MRE^(A) 65^(B) C^(C)

(A) MR = positive temperature without defrost

MRE = negative temperature with defrost

(B) Model

(C) Fin spacing: R = 4.23 mm (positive) E = 4.23 mm (negative)

L = 6.35 mm (positive) C = 6.35 mm (negative)

The MR | MRE is available with CO₂, A2Ls, HFCs and glycol water. For more information, please consult our software.

MR | MRE

6.35 mm

CONDITIONS	REFRIGERANTS	MR ... L
SC2 (1)	CO ₂ - 60 bar (2)	W
	CO ₂ - 80 bar	W
	R449A	W
Connections HFCs	Inlet (3)	Ø ODF
	Outlet (3)	Ø ODF

	65	100	120	140	170	190	250
	540	780	1130	1290	1560	1780	2390
	470	680	1010	-	1430	1640	2220
	620	880	1230	1380	1690	1940	2550
	1/2" 12mm	1/2" 12mm	1/2" 12mm	D 1/2" *	D 1/2" *	D 1/2" *	D 1/2" *
	3/8" 10mm	3/8" 10mm	3/8" 10mm	1/2" 12mm	1/2" 12mm	1/2" 12mm	1/2" 12mm

CONDITIONS	REFRIGERANTS	MRE ... C
SC3 (1)	CO ₂ - 60 bar (2)	W
	CO ₂ - 80 bar	W
	R449A	W
SC4 (1)	CO ₂ - 60 bar (2)	W
	CO ₂ - 80 bar	W
	R449A	W
Connections HFCs	Inlet (3)	Ø ODF
	Outlet (3)	Ø ODF

	65	100	120	140	170	190	250
	460	670	960	1090	1320	1500	2000
	410	590	870	-	1210	1390	1850
	450	610	900	1040	1260	1460	1950
	370	540	780	890	1080	1230	1640
	320	450	690	-	970	1120	1480
	350	490	720	820	1000	1170	1590
	1/2" 12mm	1/2" 12mm	D 1/2" *	D 1/2" *	D 1/2" *	D 1/2" *	D 1/2" *
	3/8" 10mm	3/8" 10mm	1/2" 12mm	1/2" 12mm	1/2" 12mm	5/8" 16mm	3/4" 18mm

Surface area		m ²
Circuit volume		dm ³
Airflow		m ³ /h
Fan 230 V/1/50-60 Hz 1,500 rpm	Air throw (4)	m
	Ø 200 mm	Nb
	230 V/1/50 Hz	W max
		A max (5)
Electric defr. MR > option EIK MRE > standard		Nb
	230 V/1/50 Hz	W
		A
Net weight (6)		kg

	65	100	120	140	170	190	250
	2,3	2,5	4,2	4,2	5,6	7,0	9,3
	0,6	0,6	1,0	1,0	1,4	1,7	2,3
	310	660	620	960	960	930	1240
	3,0	3,7	3,5	4,1	4,1	4,0	4,5
	1	2	2	3	3	3	4
	38	76	76	114	114	114	152
	0,24	0,48	0,48	0,72	0,72	0,72	0,96
	1	1	1	1	1	1	1
	400	440	730	960	960	1200	1600
	1,8	2,0	3,3	4,4	4,4	5,5	7,3
	3	8	10	15	15	15	20

(1) Standard conditions:

SC2 / 0 °C (air inlet temp.) / -8 °C (evaporating temp.) / DT1 = 8K

SC3 / -18 °C (air inlet temp.) / -25 °C (evaporating temp.) / DT1 = 7K

SC4 / -25 °C (air inlet temp.) / -31 °C (evaporating temp.) / DT1 = 6K

(2) Operating pressure - Specific coil - Connection diameters to be defined when ordering.

(3) ODF: female to receive the tube of the same diameter.

(4) Residual air speed: 0.25 m/s.

(5) Adjustment of overload protection. For air temperatures "ti" other than +20 °C, multiply the intensities by the ratio 293/(273 + "ti") to obtain the approximate value of the intensity after the room has been brought up to temperature.

(6) Standard net weight - Specific net weight for CO2 80 bar: contact us.

* Distributor: Ø 1/2" male to solder. Connecting piece supplied for solder expansion valve Ø 12 mm.

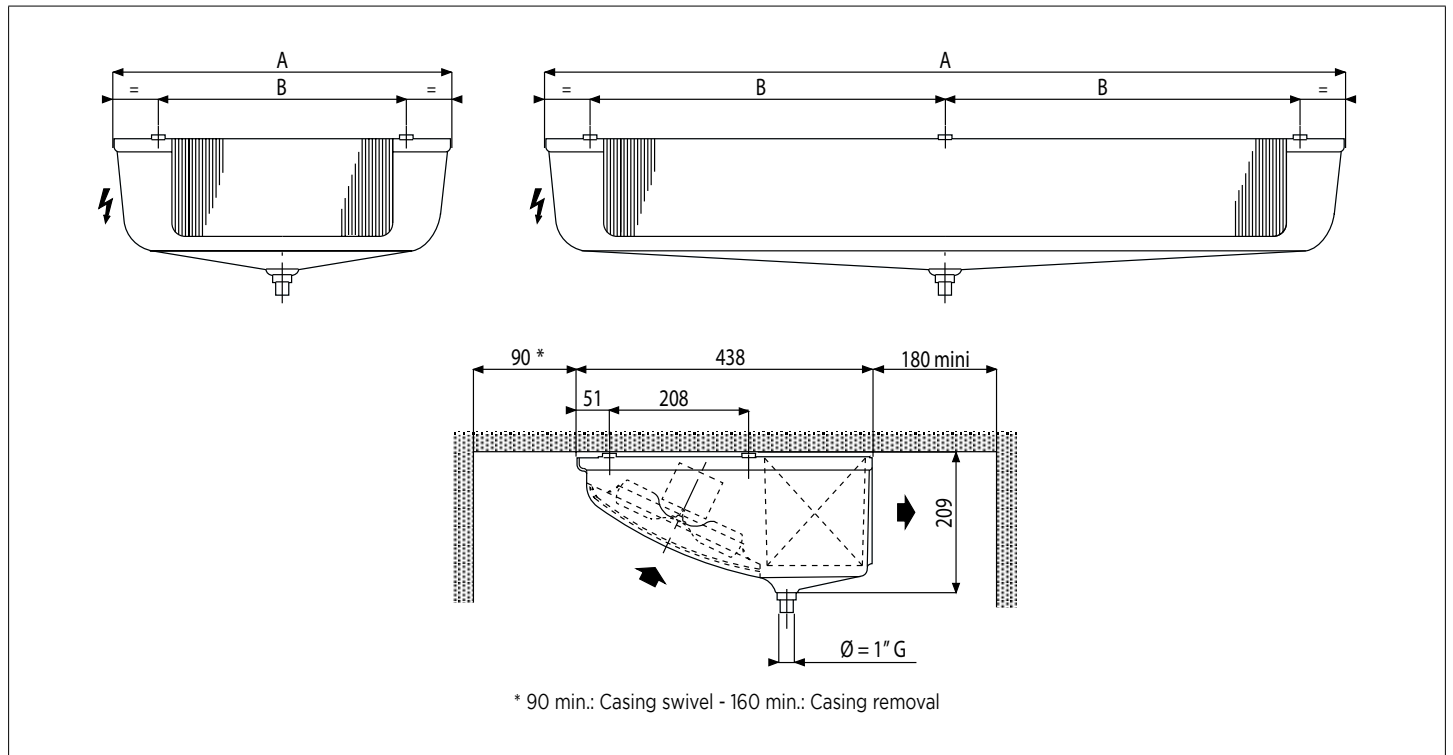

MR

MR ... R

4.23 mm

		75	110	135	160	180	210	270
A	mm	514	784	784	1174	1174	1174	1504
B	mm	326	596	596	493	493	493	658

MR ... L

6.35 mm

		65	100	120	140	170	190	250
A	mm	514	784	784	1174	1174	1174	1504
B	mm	326	596	596	493	493	493	658

MRE

MRE ... E

4.23 mm

		75	110	135	160	180	210	270
A	mm	514	784	784	1174	1174	1174	1504
B	mm	326	596	596	493	493	493	658

MRE ... C

6.35 mm

		65	100	120	140	170	190	250
A	mm	514	784	784	1174	1174	1174	1504
B	mm	326	596	596	493	493	493	658