



S-CSA+ HEX
SIZES 8 | 10 | 14



S-CSA HEX
SIZES 5 | 6



S-CSA CS
SIZES 5 | 6



S-CSA I
SIZE 6



S-CSA P
SIZE 6



S-CSA HEX A4
SIZE 8

CONCRETE SCREWS

PRODUCT DATA SHEET



HEX, CS, I, P CONCRETE SCREWS

ETA-APPROVED, HIGH PERFORMANCE CONCRETE SCREWS FROM FINLAND

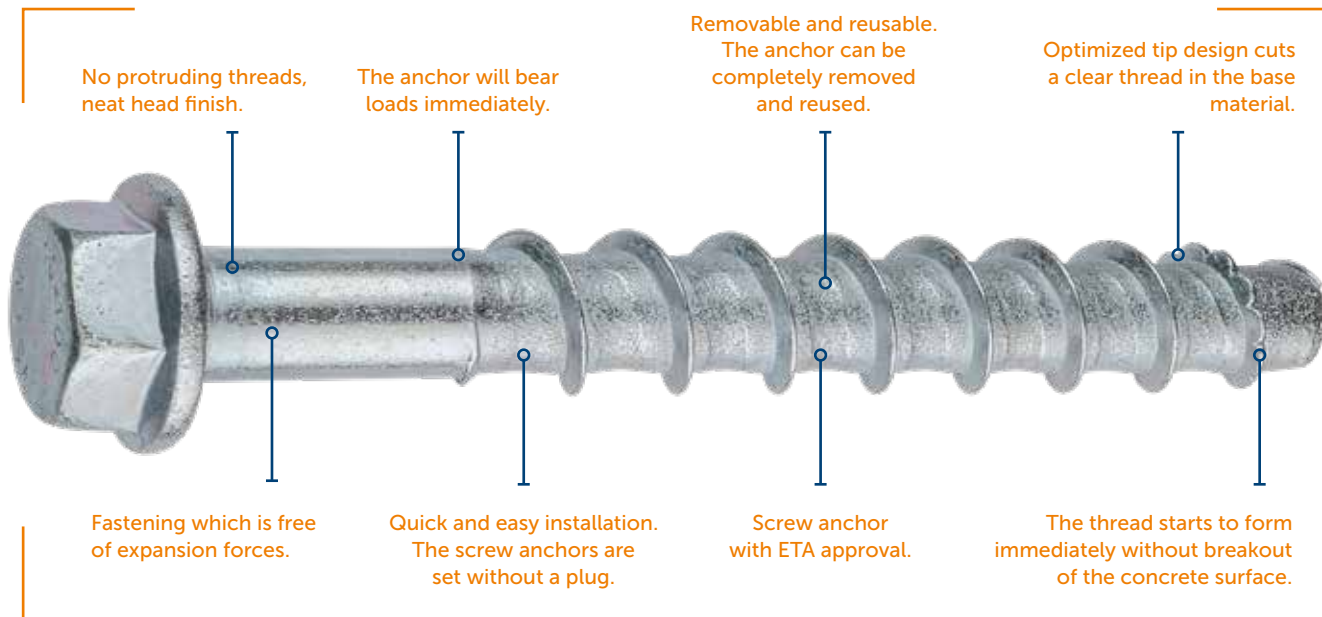

CONCRETE SCREW S-CSA

The S-CSA and S-CSA+ concrete screws are very easy and quick to install. Requires neither additional tools nor operations. It is able to take high loads even with relatively small spacings and edge distances. It is removable and reusable and therefore fits also well for temporary fixings.

Description

- Self-tapping, approved screw anchors for push-through installations.
- No expansion forces allowing for relatively small edge distances and spacings.
- ZP (zinc electro plated) for dry indoor use.
- ML (Multi Layer coated) corrosion resistant coating. S-CSA ML has been neutral salt spray tested according to DIN EN ISO 9227 (prevention of red rust for more than 1000 h)
- A4 Stainless Steel with hardened carbon steel tip, coated
- Combines the benefits of undercut and chemical anchors requiring neither additional tools and operations nor hardening time.

- S-CSA(+) HEX: hexagon head with flange
- S-CSA+ HEX WOF: hexagon head without flange
- S-CSA I: combined internal thread M8/M10
- S-CSA CS: countersunk head
- S-CSA P: pan head
- S-CSA P(L): low pan head
- S-CSA HEX A4

- The concrete screw is installed directly through the fixture into the bore hole only by screwing. By doing so, the thread is cutting itself into the concrete and that way creating a mechanical interlock over the total anchorage depth.

Benefits

- Economic installation
- Quick and easy installation
- No expansion forces
- Relatively small spacings and edge distances possible
- Removable
- Can be reused



TYPES

S-CSA+ HEX

Concrete screw with hexagonal head and flange. Sizes 8, 10, 14



S-CSA+ HEX WOF

Concrete screw with hexagonal head without flange. Size 14



S-CSA HEX

Concrete screw with hexagonal head and flange. Sizes 5, 6
Size 6 has also T-drive



S-CSA CS

Concrete screw with countersunk head and T-drive. Sizes 5, 6

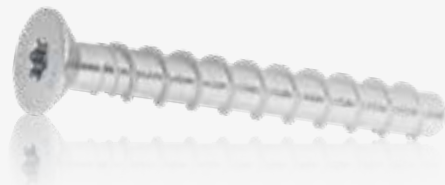

S-CSA I

Concrete screw with combined internal thread M8 / M10. Size 6



S-CSA P

Concrete screw with pan head and T-drive. Size 6

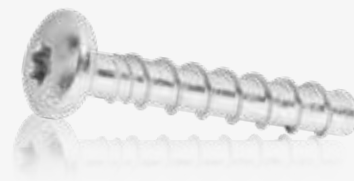

S-CSA HEX A4

Concrete screw with hexagonal head and flange. Size 8



BASE MATERIALS

Approved for



Cracked concrete



Non-cracked concrete



Hollow concrete slab

Also suitable for



Solid clay brick



Solid sand-lime brick

Description of document		Authority/ Laboratory	ID	Additional info
European Technical Assessment		ZAG -National Building and Civil Engineering Institute, Slovenia	ETA-16/0945 (S-CSA 6)	EAD 330232-01-0601, Option 1
European Technical Assessment		ZAG -National Building and Civil Engineering Institute, Slovenia	ETA-17/1009 (S-CSA 6)	Concrete screw of size 6 for multiple use in non-structural applications, EAD 330747-00-0601, (Part 6)
European Technical Assessment		ZAG -National Building and Civil Engineering Institute, Slovenia	ETA-20/0446 (S-CSA+ 8, 10, 14)	EAD 330232-01-0601, Option 1
European Technical Assessment		ZAG -National Building and Civil Engineering Institute, Slovenia	ETA-22/0413 (S-CSA 8 A4)	EAD 330232-01-0601, Option 1
General construction technique permit DIBt		DIBt	Z-21.8-2136	S-CSA+ 14 mm for temporary fastenings in concrete
Seismic resistance		ZAG -National Building and Civil Engineering Institute, Slovenia	ETA-20/0446 (S-CSA+ 8, 10, 14)	EN 1992-4
Fire resistance		ZAG -National Building and Civil Engineering Institute, Slovenia	ETA-16/0945 ETA-17/1009 ETA-20/0446 ETA-22/0413	
YouTube installation videos		Sormat Oy	Fnr5QcrK-q0	Sormat S-CSA Concrete screw installation video
Sormat Trustfix anchor calculation software		Sormat Oy / S&P Software Consulting		TrustFIX anchor calculation
CAD-blocks for AutoCAD		Sormat Oy		Blocks installation instructions for AutoCAD
ProdLib		ProdLib Oy	prodlib.com/library/sormat	CAD block library

Additional information concerning all given data in the product data sheet

- Load figures include the partial safety factors as per approvals and a partial safety factor on the action of $\gamma_F = 1.4$. Load figures apply for a rebar spacing $s \geq 15$ cm or alternatively for a rebar spacing $s \geq 10$ cm in combination with a rebar diameter of $d_s \leq 10$ mm.
- If spacings or edge distances become smaller than the characteristic figures ($s_{cr,N} / c_{cr,N}$) a calculation as per EN 1992-4 needs to be carried out. For more details, see ETA-16/0945, ETA-17/1009, ETA-20/0446 and ETA-22/0413.
- Concrete is considered non-cracked when the value of tension within the concrete is $\sigma_L + \sigma_R \leq 0$. In the absence of detailed verification $\sigma_R = 3$ N/mm² can be assumed (σ_L equals the tension within the concrete as a result of external loads, forces on anchor included; σ_R equals the tension coming from shrinkage or creep of the concrete, as well as displacements of supports or temperature variations).
- Shear load figures apply for an anchor without influence of a concrete edge. For shear loads close to an edge ($c \leq 10 \times h_{ef}$), concrete edge failure has to be checked as per EN 1992-4.

STATIC AND QUASI-STATIC LOADS

The data of these tables is based on:

- Concrete C20/25, $f_{ck,cube} = 25 \text{ N/mm}^2$.
- Installation has been done correctly (see p. 10).
- No influence of edge distances and spacings (see p. 11).
- Respect of minimum base material thickness (see p. 11).

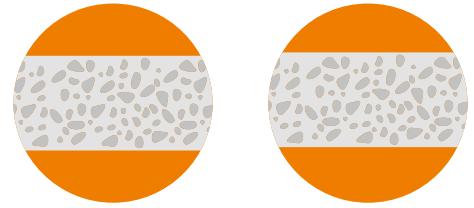

Characteristic resistances

		S-CSA 5		S-CSA 6			S-CSA+ 8		S-CSA+ 10		S-CSA+ 14		8 A4
		-	-	PART 6	PART 6	OPT 1	OPT 1	OPT 1	OPT 1	OPT 1	OPT 1	OPT 1	
Effective anchorage depth h_{ef}	[mm]	19,0	27,5	27,6	31,9	42,5	39,2	51,9	42,5	68,0	49,3	91,8	48,5
Nominal anchorage depth h_{nom}	[mm]	35	45	35	40	55	50	65	55	85	65	115	65
Non-cracked concrete													
Tension N_{Rk}	[kN]	2,4	3,5	3,0	3,5	9,5	12,1	18,4	13,6	27,6	15,0	42,0	16,6
Shear V_{Rk}	[kN]	2,4	3,5	9,4*	9,4*	9,8*	19,1*	21,5*	31,8*	35,2*	56,2	64,9*	24,3*
Cracked concrete													
Tension N_{Rk}	[kN]	NA	NA	3,0	3,5	4,5	6,5	12,0	7,5	19,0	8,5	30,0	8,5
Shear V_{Rk}	[kN]	NA	NA	9,4*	9,4*	9,5	19,1*	21,5*	28,6	35,2*	39,3	64,9*	24,3*

* Failure mode = steel

Design resistances

		S-CSA 5		S-CSA 6			S-CSA+ 8		S-CSA+ 10		S-CSA+ 14		8 A4
		-	-	PART 6	PART 6	OPT 1	OPT 1	OPT 1	OPT 1	OPT 1	OPT 1	OPT 1	
Effective anchorage depth h_{ef}	[mm]	19,0	27,5	27,6	31,9	42,5	39,2	51,9	42,5	68,0	49,3	91,8	48,5
Nominal anchorage depth h_{nom}	[mm]	35	45	35	40	55	50	65	55	85	65	115	65
Non-cracked concrete													
Tension N_{Rd}	[kN]	1,6	2,3	2,0	2,3	6,3	8,0	12,3	9,1	18,4	10,0	28,0	11,1
Shear V_{Rd}	[kN]	1,6	2,3	7,5*	7,5*	7,8*	15,3*	17,2*	25,4*	28,2*	37,5	51,9*	16,2*
Cracked concrete													
Tension N_{Rd}	[kN]	NA	NA	2,0	2,3	3,0	4,3	8,0	5,0	12,7	5,7	20,0	5,7
Shear V_{Rd}	[kN]	NA	NA	7,5*	7,5*	6,3	15,3*	17,2*	19,1	28,2*	26,2	51,9*	16,2*

* Failure mode = steel

Recommended loads

		S-CSA 5		S-CSA 6			S-CSA+ 8		S-CSA+ 10		S-CSA+ 14		8 A4
		-	-	PART 6	PART 6	OPT 1	OPT 1	OPT 1	OPT 1	OPT 1	OPT 1	OPT 1	
Effective anchorage depth h_{ef}	[mm]	19,0	27,5	27,6	31,9	42,5	39,2	51,9	42,5	68,0	49,3	91,8	48,5
Nominal anchorage depth h_{nom}	[mm]	35	45	35	40	55	50	65	55	85	65	115	65
Non-cracked concrete													
Tension N_{Rec}	[kN]	1,1	1,7	1,4	1,7	4,5	5,7	8,8	6,5	13,1	7,1	20,0	7,9
Shear V_{Rec}	[kN]	1,1	1,7	5,4*	5,4*	5,6*	10,9*	12,3*	18,2*	20,1*	26,8	37,1*	11,6*
Cracked concrete													
Tension N_{Rec}	[kN]	NA	NA	1,4	1,7	2,1	3,1	5,7	3,6	9,0	4,0	14,3	4,0
Shear V_{Rec}	[kN]	NA	NA	5,4*	5,4*	4,5	10,9*	12,3*	13,6	20,1*	18,7	37,1*	11,6*

* Failure mode = steel

BASIC LOADING DATA FOR PRECAST PRE-STRESSED HOLLOW CORE SLABS

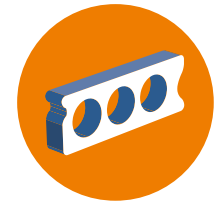

The data of these tables is based on:

- Concrete C30/37 to C50/60
- Installation has been done correctly (see page 7).
- Edge distances and spacings acc. page 7.
- The data of these tables is based on ETA-17/1009 (S-CSA 6).

Characteristic resistances

			S-CSA 6		
Nominal anchorage depth	h_{nom}	[mm]	35 / 40		
Flange thickness	d_b	[mm]	≥ 25	≥ 30	≥ 40
Load for all directions	F_{Rk}	[kN]	2,5	3,5	5,0
Char. bending resistance	$M_{Rk,s}^0$	[Nm]	16,0		
Edge distance	$c_{cr} = c_{min}$	[mm]	100		
Spacing	$s_{cr} = s_{min}$	[mm]	100		

Design resistances

			S-CSA 6		
Nominal anchorage depth	h_{nom}	[mm]	35 / 40		
Flange thickness	d_b	[mm]	≥ 25	≥ 30	≥ 40
Load for all directions	F_{Rd}	[kN]	1,7	2,3	3,3
Design bending resistance	$M_{Rd,s}$	[Nm]	12,8		
Edge distance	$c_{cr} = c_{min}$	[mm]	100		
Spacing	$s_{cr} = s_{min}$	[mm]	100		

Recommended loads

			S-CSA 6		
Nominal anchorage depth	h_{nom}	[mm]	35 / 40		
Flange thickness	d_b	[mm]	≥ 25	≥ 30	≥ 40
Load for all directions	F_{rec}	[kN]	1,2	1,7	2,4
Rec. bending load	M_{rec}	[Nm]	9,1		
Edge distance	$c_{cr} = c_{min}$	[mm]	100		
Spacing	$s_{cr} = s_{min}$	[mm]	100		

The partial safety factor for action is $\gamma = 1.4$.

Requirements for multiple anchoring

The definition of redundant fastening according to Member States is given in the EAD 330747 § 1.2.1. In Absence of definition by Member State the following default values may be taken.

Minimum number of fixing points	Minimum number of anchors per fixing point	Maximum design load of action N_{sd} per fixing point
3	1	2 kN
4	1	3 kN

The value N_{sd} might be increased if in the design it is shown that the requirements on the strength and stiffness of the fixture in the serviceability and ultimate states after the failure of one anchor are fulfilled.

INSTALLATION INSTRUCTIONS IN PRE-STRESSED HOLLOW CORE SLABS

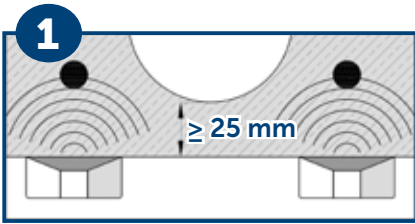

1. Locate rebars by means of suitable detector

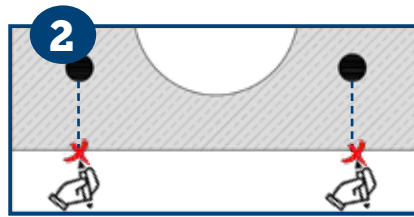

2. Mark rebar location

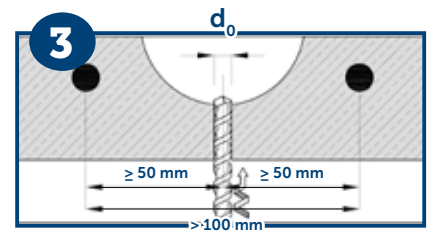

3. Make a cylindrical hole

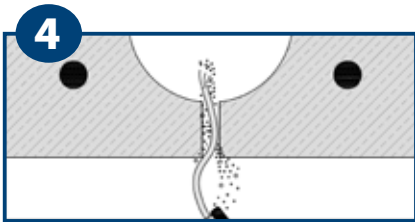

4. Clean the hole

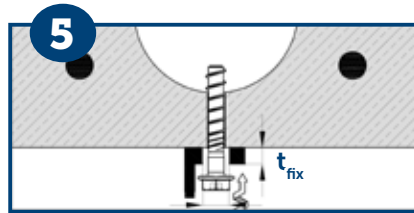

5. Install the screw anchor very gently by screwdriver or torque wrench. Avoid overtightening.

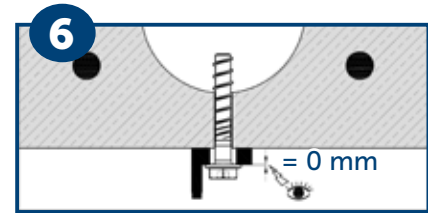

6. Ensure that the screw anchor head fully rests without any gap on the fixture and is not damaged

Admissible anchor position in pre-stressed hollow core slabs

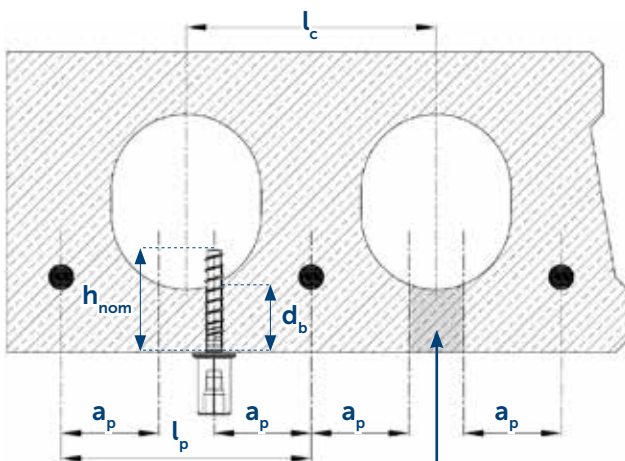

o Admissible anchor position

- Core distance $l_c \geq 100 \text{ mm}$
- Pre-stressing steel distance $l_p \geq 100 \text{ mm}$
- Distance between anchor position and pre-stressing steel $a_p \geq 50 \text{ mm}$

Minimum spacing and edge distance of anchors and distance between anchor groups in pre-stressed hollow core slabs



- Minimum edge distance $c_{\min} \geq 100 \text{ mm}$
- Minimum anchor spacing $s_{\min} \geq 100 \text{ mm}$
- Minimum distance between anchor groups $a_{\min} \geq 100 \text{ mm}$

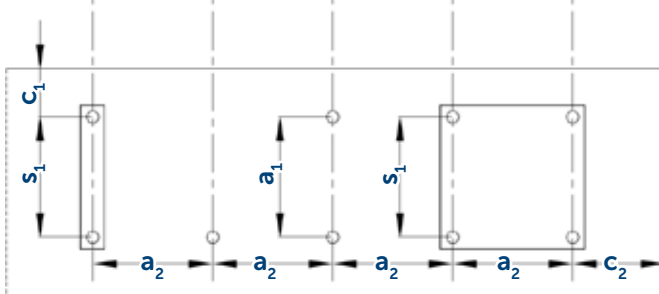

- c1, c2 edge distance
- s1, s2 anchor spacing
- a1, a2 distance between anchor groups

SEISMIC RESISTANCE

Design acc. EN 1992-4 Performance category C2

The data of these tables is based on:

- Concrete C20/25, $f_{ck,cube} = 25 \text{ N/mm}^2$
- Installation has been done correctly
- No influence of edge distances and spacings
- Respect of minimum base material thickness
- $\alpha_{gap} = 1,0$ (used with seismic filling washer, concerns only the shear values)
- ETA-20/0446 (S-CSA+)



Characteristic resistances

Anchor size		8-2	10-2	14-2
Effective anchorage depth h_{ef}	[mm]	51,9	68,0	91,8
Cracked concrete				
<i>Tension</i> $N_{Rk, se}$	[kN]	1,9	3,8	6,9
<i>Shear</i> $V_{Rk, se}$	[kN]	13,6*	24,6*	41,5*

Design resistances

Anchor size		8-2	10-2	14-2
Effective anchorage depth h_{ef}	[mm]	51,9	68,0	91,8
Cracked concrete				
<i>Tension</i> $N_{Rd, se}$	[kN]	1,3	2,5	4,6
<i>Shear</i> $V_{Rd, se}$	[kN]	10,9*	19,7*	33,2*

Recommended loads

Anchor size		8-2	10-2	14-2
Effective anchorage depth h_{ef}	[mm]	51,9	68,0	91,8
Cracked concrete				
<i>Tension</i> $N_{Rec, se}$	[kN]	0,9	1,8	3,3
<i>Shear</i> $V_{Rec, se}$	[kN]	7,8*	14,1*	23,7*

α_{seis} and α_{gap} included as per EN 1992-4. The shear values consider filling of the annular gap between the anchor and the fixture.

* Failure mode = steel

FILLING WASHER

For seismic applications
Installation with S-CSA+ concrete screw



When selecting a S-CSA+ concrete screw, please note that the use of the Filling Washer reduces the fixture thickness t_{fix} of the concrete screw



1.

1. Mount matching Filling Washer additionally to Concrete Screw



2.

2. Drive in Concrete Screw with Filling Washer until the anchorage depth h_{nom} is reached



3.

3. Stick mixer reducer tip on static mixer nozzle.
Adhesive tape can be used if necessary.



4.

4. Fill the annular gap between Concrete screw and fixture through the hole of the Filling Washer until resin leaks out of this hole.

Please observe installation instructions of injection resin. Load may only be applied after the curing time of the injection resin is reached.

Filling Washer is used for filling the gap between fixture and concrete screw after it has been set.

After installation, the Sormat ITH resin is injected using the mixer reducer tip (included) until resin seeps out.

S-CSA+ concrete screw	8	10	14
Filling washer size	26x12x5	28x14x5	34x17x5
Reduction of fixture thickness t_{fix}	$t_{fix} - 5 \text{ mm}$	$t_{fix} - 5 \text{ mm}$	$t_{fix} - 5 \text{ mm}$

Design under fire exposure is performed according to the design method given in EN 1992-4.

The data of these tables is based on: ETA-16/0945, ETA-17/1009, ETA-20/0446 and ETA-22/0413

- Concrete C20/25, $f_{ck,cube} = 25 \text{ N/mm}^2$
- Values cannot be used with hollow core slabs
- Installation has been done correctly (p.12)
- No influence of edge distances and spacings (p. 13)
- Respect of minimum base material thickness (p. 13)



Characteristic resistances

		S-CSA 6			S-CSA+ 8		S-CSA+ 10		S-CSA+ 14		S-CSA 8 A4
		PART 6	PART 6	OPT 1	OPT 1		OPT 1		OPT 1		OPT 1
Effective anchorage depth h_{ef}	[mm]	27,6	31,9	42,5	39,2	51,9	42,5	68,0	49,3	91,8	48,5
Nominal anchorage depth h_{nom}	[mm]	35	40	55	50	65	55	85	65	115	65

Fire Exposure R30

Tension $N_{Rk, s, fi}$	[kN]	0,24	0,24	0,24	0,42	0,42	0,99	0,99	2,13	2,65	0,85
Shear (steel failure) $V_{Rk, s, fi}$	[kN]	0,24	0,24	0,24	0,42	0,42	0,99	0,99	2,65	2,65	0,85

Fire Exposure R60

Tension $N_{Rk, s, fi}$	[kN]	0,22	0,22	0,22	0,38	0,38	0,85	0,85	1,99	1,99	0,68
Shear (steel failure) $V_{Rk, s, fi}$	[kN]	0,22	0,22	0,22	0,38	0,38	0,85	0,85	1,99	1,99	0,68

Fire Exposure R90

Tension $N_{Rk, s, fi}$	[kN]	0,17	0,17	0,17	0,30	0,30	0,66	0,66	1,73	1,73	0,51
Shear (steel failure) $V_{Rk, s, fi}$	[kN]	0,17	0,17	0,17	0,30	0,30	0,66	0,66	1,73	1,73	0,51

Fire Exposure R120

Tension $N_{Rk, s, fi}$	[kN]	0,12	0,12	0,12	0,21	0,21	0,53	0,53	1,33	1,33	0,42
Shear (steel failure) $V_{Rk, s, fi}$	[kN]	0,12	0,12	0,12	0,21	0,21	0,53	0,53	1,33	1,33	0,42

The recommended loads under fire exposure include a safety factor for resistance under fire exposure $\gamma_{M,fi} = 1,0$ and the partial safety factor for action $\gamma_{F,fi} = 1,0$. The partial safety factors for action shall be taken from national regulations.

MATERIALS AND DIMENSIONS

Material quality and coating

Part	
Material	Cold forged carbon steel or cold forged stainless steel A4
Coating ZP	Zinc electroplated according to EN ISO 4042 $\geq 5 \mu\text{m}$
Coating ML	Multi Layer coating $\geq 8 \mu\text{m}$

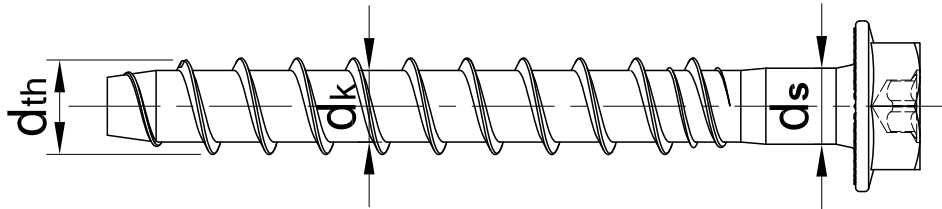

Mechanical properties

Specification		S-CSA 5		S-CSA 6			S-CSA+ 8		S-CSA+ 10		S-CSA+ 14		S-CSA 8 A4
Effective anchorage depth h_{ef}	[mm]	19	27,5	27,6	31,9	42,5	39,2	51,9	42,5	68	49,3	91,8	48,5
Nominal anchorage depth h_{nom}	[mm]	35	45	35	40	55	50	65	55	85	65	115	65
Nominal Tension strength F_{uk}	[N/mm ²]	800		800			800		800		800		800
Char. bending resistance $M_{Rk,s}^0$	[Nm]	8,6		16			37	45	72	84	207	227	45,6
Design bending resistance $M_{Rd,s}$	[Nm]	5,7		12,8			29,6	36	57,6	67,2	165,6	181,6	30,4
Recommended bending resistance M_{rec}	[Nm]	4,1		9,1			21,1	25,7	41,1	48	118,3	129,7	21,7

Specification		S-CSA 5		S-CSA 6	S-CSA+ 8	S-CSA+ 10	S-CSA+ 14	S-CSA 8 A4
Nominal diameter	d_{nom}	5,0		6,0	8,0	10,0	14,0	80
Thread outer diameter	d_{th}	6,12		7,45	10,50	12,70	16,55	9,9
Core diameter	d_k	4,50		5,55	7,30	9,15	13,00	7,35
Shaft diameter	d_s	4,9		5,88	7,80	9,62	13,40	7,85
Stressed section	A_s	15,9		24,19	42,43	65,76	132,73	42,43
Diameter of flange (HEX)	D	11,5		16,5	17,5	20,5	28/29,5	17,5
Diameter of flange (I)	D	-		14,2	-	-	-	-
Diameter of pan head (P)	D	-		14,5	-	-	-	-
Diameter of countersunk (CS)	D	9,8		14	-	-	-	-

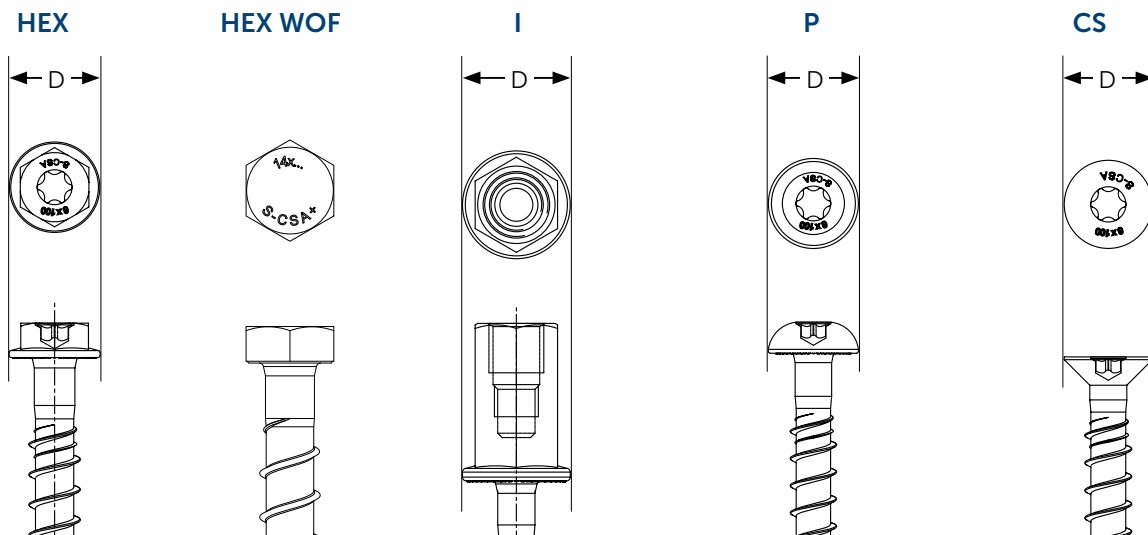

Installation equipment

Specification	S-CSA 5	S-CSA 6	S-CSA+ 8	S-CSA+ 10	S-CSA+ 14	S-CSA 8 A4
Rotary hammer	750...1200 r.p.m / 1.8 ...3.3 J					
Drill bit	SDS+ 2-CUT or 4-CUT sizes 5, 6, 8, 10, 14 mm					
Socket (SW) [mm]	8	13	13	15	21 or 24	13
T-drive / Torx	T25	T30	-	-	-	-
Additional tools	air pump/compressor, torque wrench, impact screw driver					

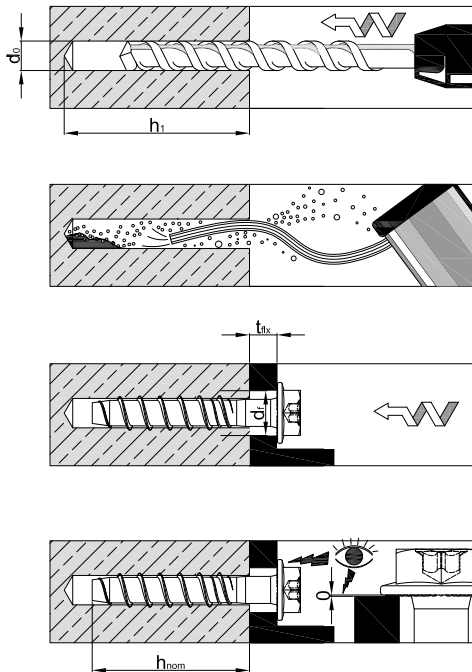

NOTES:

CONCRETE AND HOLLOW CORE SLAB

- Concrete strength is C20/25 to C50/60
Hollow core slabs C30/37 to C50/60
- No significant voids in concrete.
- Concrete is well compacted.
- Thickness of concrete is according PDS installation data.

INSTALLATION

Edge distances and spacing are according PDS installation data.

- Use proper air pump or compressor.
- Drill hole is deep enough (mentioned h_1 in PDS installation data).
- All dust should be cleaned from the hole to avoid screw jamming during installation.
- Pay special attention to cleaning, especially when installing downwards.
- In case of aborted hole, drilling of new hole at a minimum distance of twice the depth of the aborted hole, or smaller distance provided the aborted drill hole is filled with high strength non-shrinkage mortar. No shear or oblique tension loads are allowed in the direction of a not filled aborted hole.

OTHER BASE MATERIALS

- Concrete screw can be used also in other base materials such as solid clay brick and solid sand-lime brick.

Installation data

Specification			S-CSA 5		S-CSA 6			S-CSA+ 8		S-CSA+ 10		S-CSA+ 14		S-CSA 8 A4
Approval			-	-	PART 6	PART 6	OPT 1	OPT 1	OPT 1	OPT 1	OPT 1	OPT 1	OPT 1	
Drill hole diameter	d_0	[mm]	5		6			8		10		14		8
Cutting diameter at the upper tolerance limit (max. diam. bit)	$d_{cut,max \leq}$	[mm]	5,40		6,40			8,45		10,45		14,50		8,45
Depth of drilled hole to deepest point	$h_{1 \geq}$	[mm]	45	55	45	50	65	60	75	65	95	75	125	75
Effective anchorage depth	h_{ef}	[mm]	19,0	27,5	27,6	31,9	42,5	39,2	51,9	42,5	68	49,3	91,8	48,5
Nominal anchorage depth	h_{nom}	[mm]	35	45	35	40	55	50	65	55	85	65	115	65
Diameter of clearance hole in the fixture	d_f	[mm]	6,3-7,0		7,7-9,0			10,8-12,0		13,0-14,0		17,0-18,0		10,2-12,0
Max. torque, manual	T_{inst}	[Nm]	12		14			45		85		100		40
Max. torque, impact screw driver	T_{SD}	[Nm]	-		90			290		650		650		200
Width across flats	SW	[mm]	8		13			13		15		21 / 24		13
T-drive (in types HEX, CS and P)	T-drive		CS	T25	T30			-		-		-		-

S-CSA ANCHOR INSTALLATION

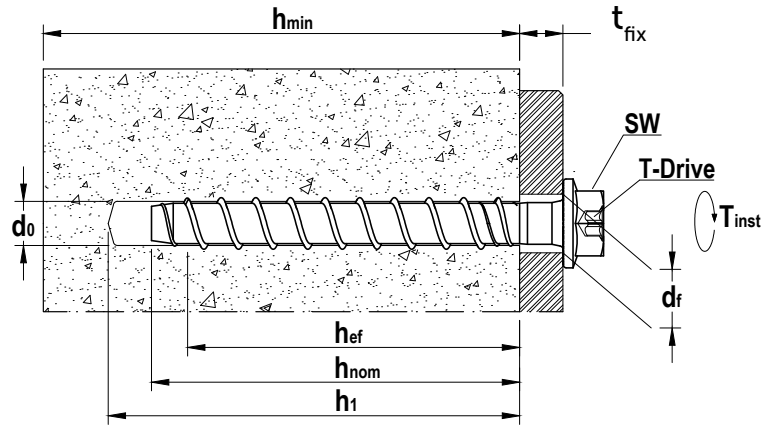

Minimum thickness of concrete member, spacing and edge distance

Cracked and non-cracked concrete		S-CSA 5		S-CSA 6			S-CSA+ 8		S-CSA+ 10		S-CSA+ 14		S-CSA HEX A4
Approval		-	-	PART 6	PART 6	OPT 1	OPT 1	OPT 1	OPT 1	OPT 1	OPT 1	OPT 1	OPT 1
Effective anchorage depth	h_{ef} [mm]	19,0	27,5	27,6	31,9	42,5	39,2	51,9	42,5	68	49,3	91,8	48,5
Nominal anchorage depth	h_{nom} [mm]	35	45	35	40	55	50	65	55	85	65	115	65
Minimum thickness of base material	h_{min} [mm]	80	80	80	100	100	100	115	100	130	120	150	100
Minimum spacing	s_{min} [mm]	35	35	35	35	35	35	35	40	40	60	60	35
Minimum edge distance	c_{min} [mm]	35	35	30	35	35	35	35	40	40	60	60	35
Critical spacing for splitting failure and concrete cone failure (in case characteristic loading affects)	$s_{cr,sp}$ [mm]	53	83	110	96	128	118	176	128	232	148	275	165
	$s_{cr,N}$ [mm]	53	83	83	96	128	118	156	128	204	148	275	145,5
Critical edge distance for splitting failure and concrete cone failure (in case characteristic loading affects)	$c_{cr,sp}$ [mm]	27	41	55	48	64	59	88	64	116	74	138	82,5
	$c_{cr,N}$ [mm]	27	41	41	48	64	59	78	64	102	74	138	72,8

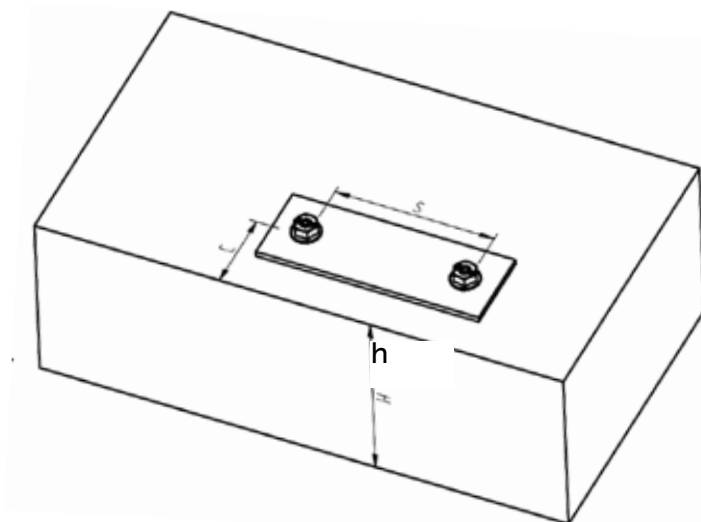

DIBt Z-21.8-2136 approves the reuse of the S-CSA+ concrete screw, 14 mm diameter with hexagon head in combination with the CG checking gauge. The checking gauge is a tool for measuring the reusability of the S-CSA+ 14 concrete screw for temporary applications. The checking must be performed before each reuse.

Field of application

S-CSA+ 14 shall only be applied for temporary fastening of construction site equipment, such as shoring props, fall protection devices or scaffolds. After it has been unscrewed, the fastener may be reused in other drill holes. However, a drilled hole shall not be reused after the fastener has been removed. Reusability of the fastener shall be checked prior to every use, both visually as well as with a sleeve gauge in accordance with installation parameters. Installed fasteners shall be checked for visible damage (for example due to corrosion) on an ongoing basis and replaced if required. The fastener may be used in cracked and non-cracked concrete. The fastener is intended for temporary use in internal and external conditions.

Installation

S-CSA+ 14 is only intended for temporary application in a single drilled hole. After it has been removed, it may be reused in other drilled holes. However, it may not be screwed into the same drilled hole for a second time. Prior to every reuse, the wear of the thread shall be verified with an appropriate sleeve gauge (CG). The fastener shall only be reused under the condition that it will penetrate the sleeve only so far that it does not protrude at the rear of the sleeve (see Annex 2). Screws which are visibly damaged, e.g. due to corrosion, shall not be reused. The fastener may be screwed in using an impact screw driver. To prevent the screw from spinning, the screw driver with a power output in the upper range shall be equipped with an automatic cut-off device, e.g. via a depth stop.

The fastener is installed correctly if

- the base plate (fixture) is screwed flush against the concrete without an intermediate layer,
- the fastener head is fully in contact with the base plate,
- the fastener cannot easily be turned further,
- the embedment depth h_{nom} is adhered to.

Anchor size	S-CSA+ 14			
Nominal embedment depth	h_{nom}	[mm]	65	115
Design resistance for concrete with a compressive strength $f_{ck,cube} \geq 10 \text{ N/mm}^2$	$F_{Rd}^{1)}$	[kN]	2,7	6,7
Design resistance for concrete with a compressive strength $f_{ck,cube} \geq 15 \text{ N/mm}^2$	$F_{Rd}^{1)}$	[kN]	3,0	8,0
Design resistance for concrete with a compressive strength $f_{ck,cube} \geq 20 \text{ N/mm}^2$	$F_{Rd}^{1)}$	[kN]	3,0	9,3
Design resistance for concrete with a compressive strength $f_{ck,cube} \geq 25 \text{ N/mm}^2$	$F_{Rd}^{1)}$	[kN]	3,3	10,0

¹⁾ Design resistance incl. partial safety factor.

S-CSA+ 14 REUSABILITY

Checking gauge CG



Gauge

Gauge inner diameter d_c 15,5 [mm]

Length l_c 40,0 [mm]

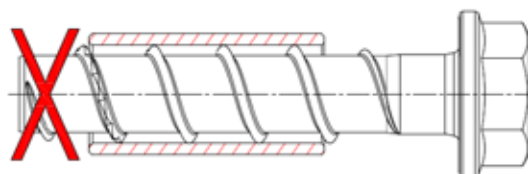
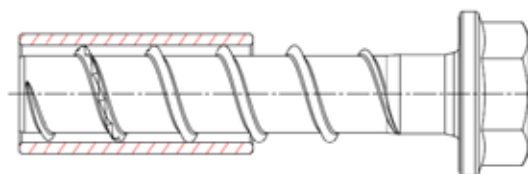
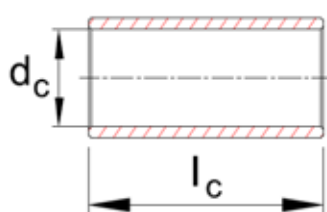

DELIVERY PROGRAM

HEX, CS, I, P CONCRETE SCREWS

S-CSA+ HEX		Size	t _{fix}	ETA
8		8x55	5	●
		8x70	5/20	●
		8x80	15/30	●
		8x90	25/40	●
		8x100	35/50	●
		8x120	55/70	●
		8x140	75/90	●
10		10x60	5	●
		10x70	15	●
		10x80	25	●
		10x90	5/35	●
		10x100	15/45	●
		10x120	35/65	●
		10x140	55/85	●
		10x160	75/105	●
14		14x75 SW21	10	●
		14x100 SW21	35	●
		14x130 SW21	15/65	●
		14x150 SW21	35/85	●
		14x80 SW24 (WOF) *	15	●
		14x110 SW24 *	45	●
		14x130 SW24 *	15/65	●

Zinc plated or Multi Layer coating, * = Only ZP

S-CSA+ HEX 14 checking gauge for re-usability



S-CSA HEX		Size	t _{fix}	ETA
5		5x40 *	5	-
		5x50 *	5	-
6		6x35	1	●
		6x45	5/10	●
		6x50	10/15	●
		6x60	5/20	● ●
		6x70	15/30	● ●
		6x80	25/40	● ●
		6x100	45/60	● ●
		6x120	65/80	● ●
		6x140	85/100	● ●

Zinc plated or Multi Layer coating, * = Only ZP

S-CSA CS		Size	t _{fix}	ETA
5		5x50 *	5	-
		5x75 *	30	-
		5x100 *	55	-
6		6x45	5/10	●
		6x50	10/15	●
		6x60	5/20	● ●
		6x80	25/40	● ●
		6x100	45/60	● ●
		6x120	65/80	● ●

Zinc plated or Multi Layer coating, * = Only ZP

S-CSA P		Size	t _{fix}	ETA
6		6x35 (L)	1	●
		6x45 (L)	5	●
		6x60	5/20	● ●

Zinc plated, L = Low pan head

S-CSA I		Size	ETA
6		6x35 M8/M10x30	●
		6x45 M8/M10x30	●
		6x60 M8/M10x30	● ●

Zinc plated

S-CSA HEX A4		Size	t _{fix}	ETA
8		8x70	5	●
		8x80	15	●
		8x100	35	●

Stainless Steel A4, hardened tip, coated

● Option 1 ● Part 6