

Installation guide

Tube-in-tube heat exchanger

HE

015R9711

015R9711

Refrigerants:

R22, R1270*, R134a, R290*, R404A, R407A, R407C, R407F, R448A, R449A, R450A, R452A, R507A, R513A, R600*, R600a*

*) Applicable for HE 0.5, HE 1.0 and HE 1.5 only.

For complete list of approved refrigerants, visit www.products.danfoss.com and search for individual code numbers, where refrigerants are listed as part of technical data.

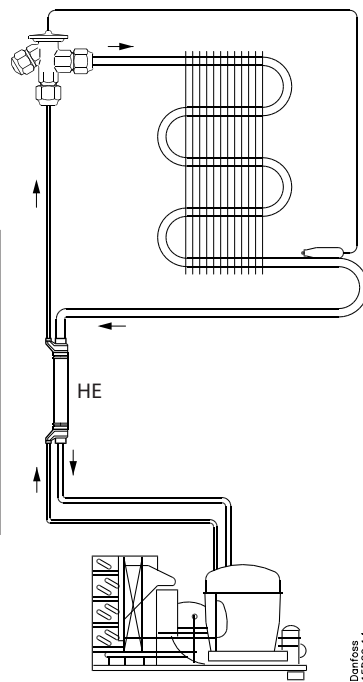
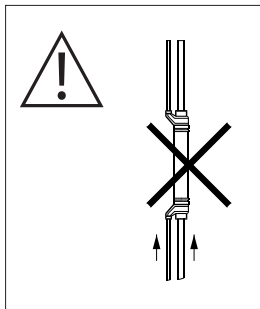
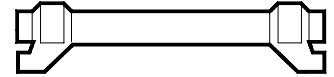

Type	HE 0.5, HE 1.0, HE 1.5, HE 4.0	HE 8.0
Max. working pressure PS/MWP	28 bar/406 psig	21.5 bar/312 psig
Max. test pressure (one time)	40 bar/580 psig	28 bar/406 psig
Temperature range	-60 – 120 °C (-76 – 248 °F)	

Silver flo 55 + Easy flow flux

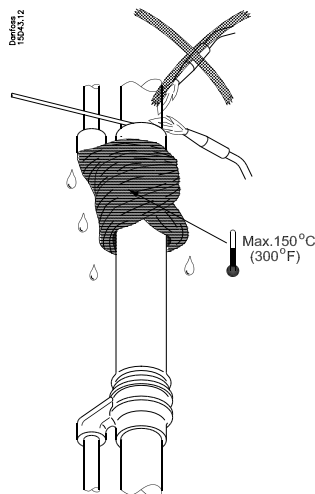

Max. 150 °C (300 °F)